

# Bi-Convex Lenses

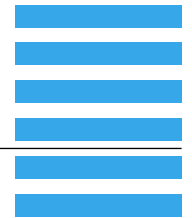

The convex surfaces of these lenses are symmetric with the focal length equal to the radius of curvature. Because of their symmetric shape they have good performance for imaging close to 1 and magnifications from 5 to 0,2.

Another advantage over plano convex lenses is a shorter focal length at higher aperture ratio (because both convex surfaces contribute to the magnifying power). Choose one of these lenses for beam focussing for a short optical path, particularly where image quality or spot size is not critical.

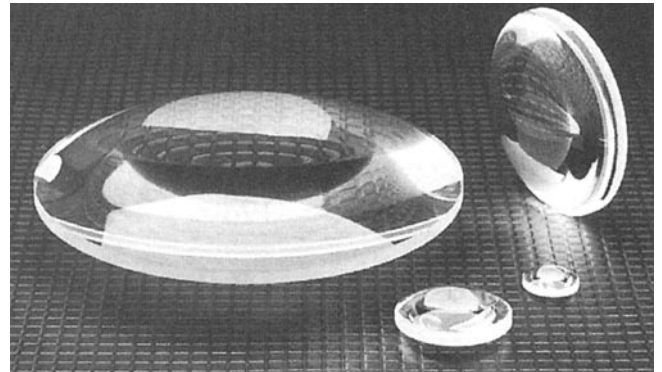

## Focal length at other wavelengths

The focal length changes as a function of wavelength (dispersion). To find the focal length at other wavelengths as listed below, multiply the focal length at 589 nm (listed in the ordering info) by the factor in the following table.

Wavelength (nm)	Factor	
	Quartz	Glass
190	0,81	-
250	0,90	-
488	0,99	0,989
633	1,003	1,003
850	1,013	1,014
1050	1,02	1,02
2000	1,05	1,05

Specifications		
Tolerance	diameter:	+0 mm; -0,25 mm
	focal length:	±2%
	back focal length:	±2%
Usable Aperture	95% of diameter	
Substrate	BK 7 bzw. B 270, Suprasil® 2	
Index of Refraction	BK 7:	1,5167 @ 589 nm
	B 270:	1,5230 @ 589 nm
	Suprasil®:	1,4584 @ 589 nm
Surface Accuracy Error	1 – 2 λ	
Centration	within 1 – 2 min	

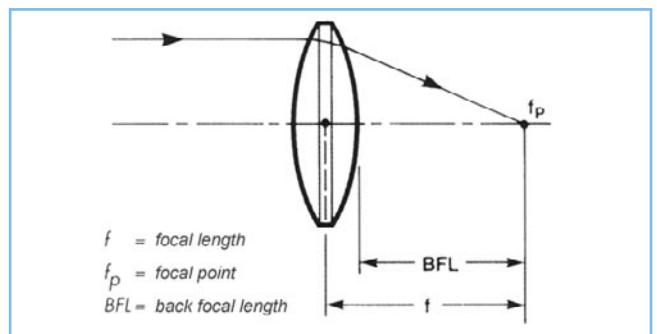

## Ordering Information

Ø (mm)	f		Quartz		Glass	
	nominal @ 589 nm	F-Number	BFL nominal @ 589 nm	Order No.	BFL nominal @ 589 nm	Order No.
12,7	10	0,8	7,6	3-39301	9,0	3-39201
	13	1,0	11,2	3-39302	12,2	3-39202
	16	1,3	14,2	3-39303	15,4	3-39203
	20	1,5	18,8	3-39304	19,5	3-39204
	28	2,0	27,0	3-39305	25,6	3-39205
	38	3,0	37,2	3-39306	37,7	3-39206
	51	4,0	50,1	3-39307	50,7	3-39207
25,4	20	0,8	15,3	3-39311	18,0	3-39211
	28	1,0	24,6	3-39312	24,6	3-39212
	32	1,3	29,3	3-39313	60,7	3-39213
	38	1,5	35,7	3-39314	37,0	3-39214
	51	2,0	49,2	3-39315	50,2	3-39215
	63	2,5	61,5	3-39316	62,3	3-39216
	76	3,0	74,6	3-39317	75,2	3-39217
	101	4,0	99,6	3-39318	100,3	3-39218

# Bi-Convex Lenses

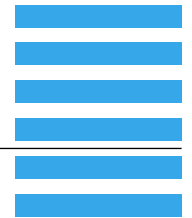

Ø (mm)	f		Quartz		Glass	
	nominal @ 589 nm	F-Number	BFL nominal @ 589 nm	Order No.	BFL nominal @ 589 nm	Order No.
38,1	32	0,85	25,2	3-39321	29,4	3-39221
	38	1,0	33,2	3-39322	36,0	3-39222
	51	1,3	47,3	3-39323	49,4	3-39223
	63	1,68	60,0	3-39324	61,7	3-39224
	76	2,0	73,5	3-39325	74,8	3-39225
	101	2,7	98,9	3-39326	100,0	3-39226
	128	2,7	126,3	3-39327	125,6	3-39227
50,8	39	0,85	27,9	3-39331	34,2	3-39231
	51	1,0	44,2	3-39332	48,4	3-39232
	64	1,25	58,9	3-39333	61,0	3-39233
	76	1,5	71,8	3-39334	74,0	3-39234
	101	2,0	97,8	3-39335	100,0	3-39235
	126	2,5	123,3	3-39336	125,3	3-39236
	176	3,5	173,8	3-39337	174,4	3-39237
	252	5,0	249,8	3-39338	250,5	3-39238
76,2	64	0,85	51,1	3-39341	59,2	3-39241
	78	1,0	68,5	3-39342	72,0	3-39242
	101	1,3	94,0	3-39343	98,1	3-39243
	126	1,7	120,3	3-39344	124,0	3-39244
	176	2,3	171,9	3-39345	173,7	3-39245
101,6	101	1,0	88,9	3-39346	96,7	3-39246