



Arc Light Sources

50 – 150 W Arc Light Source

- designed for arc lamps
- convection cooling
- precision external lamp adjustments
- choice of different UV-NIR condensing optics for collimated beam
- supports wide range of accessories

Modular Construction

This housing was especially designed for arc lamps. But it operates different sources as well:

- Xe and Hg arc lamps up to 150 W
- Halogen lamps up to 150 W
- 30 W Deuterium lamps

Changing within one lamp category requires only a new lamp adapter to position the lamp in the center of the housing.

Changing from one category to another, for example from arc lamps to halogen lamps, requires a simple change of Interface to meet the different electrical requirements of each lamp type. Arc lamps need two high voltage connections. Deuterium lamps need three connectors. All Interfaces include cables to connect to our power supplies.

Our lamp housings have height adjustable feet which allow adjusting the optical axis by 15 mm. You can take the feet off and hard mount the housing to a bench, rail or optical table with the optics axis centered over the hole pattern to allow for easy integration with the rest of your setup. The height of the optical axis then is 133 mm.

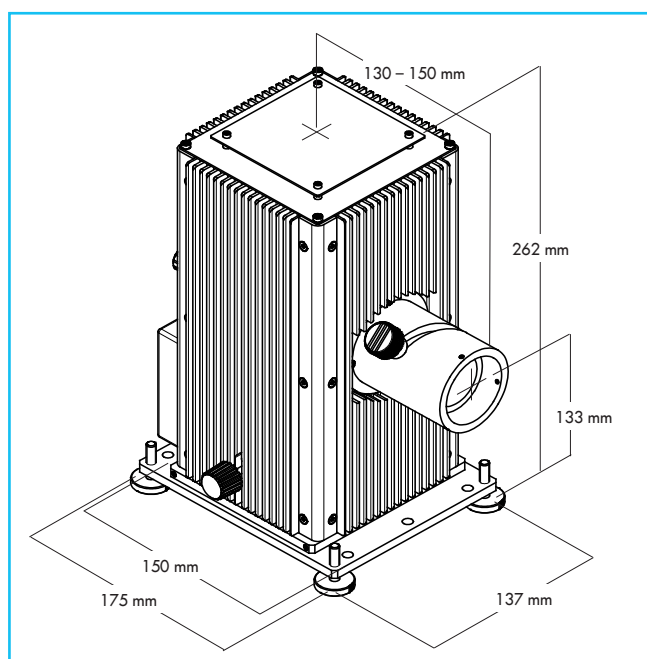

Convection Cooling

Unlike fan cooled housings, this housing uses natural convection cooling. This type of cooling is best because of acoustically quiet and vibration free, resulting in a more stable lamp output.

Openings in the bottom and top of the housing allow air to enter and circulate through the housing without excessive light leakage. The ribbed exterior improves cooling efficiency.

Condensing Optic

We offer a choice of several condensers with 35 mm aperture; they differ in:

- lens material and therefore usable spectral range
- F/number and therefore beam quality and collection/collimation efficiency

The condensers are intended for collimated beams, but can also be positioned for compensating focal length change due to dispersion and to produce a more diverging or converging beam.

For best uniformity use a slightly diverging beam. For best quality images use the condenser as a collimator and a secondary focusing lens.

The condenser lenses are made of high quality UV Quartz for transmission down to 200 nm, or optical borosilicate glass (BK7; B270) for applications, where output below 360 nm is not required.

For transmittance of these materials go to www.lot-oriel.com/lightsources („Basics“).

Arc Light Sources

50 – 150 W Arc Light Source

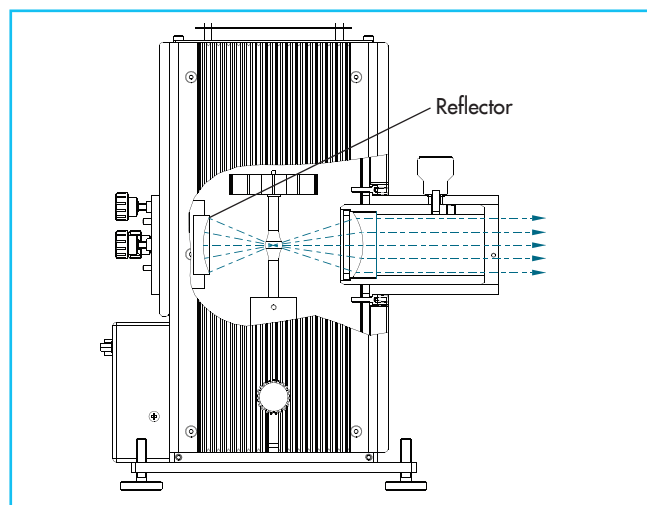

More Light

The optional Reflector Assembly collects additional radiation from the source, increasing output by up to 50 % for arc lamps. You also get significantly more output with halogen lamps. The reflectors are not for use with the deuterium lamps. Each reflector assembly includes a wide-band AlMgF₂ coated mirror, usable from the UV to IR. Control knobs provide x, y, and z adjustments for tilt and focus.

Lamp Adjustment

The housing has precise external lamp adjusters. They let you place the arc where you want it. This is important while simplifying fiber and slit illumination. In many applications this removes the need for readjusting any optics sitting in the beam after it leaves the housing.

A Word on Safety

When using arc lamps you have to operate the housing only with a condenser or window because of possible lamp burst! Even with these low powered sources, UV radiation and ozone are a concern. The easiest solution to the ozone problem is to use an ozone free arc lamp if you do not need output below 260 nm. If that is not an option, vent the ozone. Take appropriate UV safety precautions; enclose the beam or wear UV protective eyewear and gloves.

For more about UV safety go to „Ultraviolet Safety Considerations“ on www.lot-orient.com/lightsources („Basics“).

Ordering Information

To build a complete light source you will need: Lamp housing, condensing optics, lamp with appropriate adapter, electrical interface, cable and power supply. As an option we suggest the rear reflector for more output.

Housing and Optics

LSH102	Housing
LSC115	UV Quartz Condenser; F/1,3; 35 mm aperture
LSC110	UV Quartz Condenser; F/1,0; 35 mm aperture
LSC111	Glass Condenser; F/1,0; 35 mm aperture
LSC116	Glass Condenser; F/1,3; 35 mm aperture
LSC121	Rear Reflector Assembly

for Transmittance of Materials go to www.lot-orient.com/lightsources, („Basics“).

Lamps and Adapters

	Arc lamps	Required Adapter
LSB605	50 W Hg	LSA120
LSB610	100 W Hg	LSA121
LSB710	100 W Hg(Xe)	LSA122
LSB711	150 W Hg(Xe)	LSA123
LSB510	75 W Xe	LSA122
LSB511	75 W Xe OF	LSA122
LSB512	100 W Xe OF	LSA122
LSB520	150 W Xe	LSA123
LSB521	150 W Xe OF	LSA123
LSB522	150 W Xe UV	LSA123

For lamp specifications go to www.lot-orient.com/lightsources („Arc Light Sources“)

Power Supplies and Interfaces

LSN150	Power Supply for 50 – 150 W Arc Lamps
LSN151	Power Supply for 75 W Xe Lamps
LSN152	Power Supply for 100 W Xe Lamps
LSN153	Power Supply for 150 W Xe Lamps
LSN160	Power Supply for 50 W Hg Lamps
LSN161	Power Supply for 100 W Hg Lamps (requires LSE142 Interface)
LSN171	Power Supply for 100 W Hg(Xe) Lamps
LSE140	Interface for Arc Lamps
LSE142	Interface for 50/100 W Hg Lamps
LSE143	Cable Xe
LSE144	Cable Hg

For specifications of power supplies go to www.lot-orient.com/lightsources („Arc Light Sources“)