

Interfacial Water Structure studied by Vibrational

Sum Frequency Generation

Application Note

Maria Sovago, Mischa Bonn (November 2009)

Introduction

Water interfaces play a central role for a wide variety of disciplines including electrochemistry, (photo-) catalysis and biology. Despite its apparent importance, our understanding of interfacial water has lagged that achieved for bulk. A distinct challenge in the study of interfacial water lies in the specific investigation of the water molecules that participate in forming the interface, as for the majority of experimental approaches the response of the minor fraction of interfacial water molecules remains buried beneath the bulk response.

The use of Vibrational Sum Frequency Generation (VSFG) has been shown to be a very versatile tool in the study of interfacial water. In VSFG, an infrared (IR) and a visible beam are combined at an interface to generate a signal at the sum frequency of the infrared and visible frequencies. When the IR frequency is resonant with a molecular vibration, the sum-frequency signal is strongly enhanced. As such, VSFG allows one to record the vibrational spectrum of the outermost monolayer of an otherwise centrosymmetric material.

Experimental Setup

An overview of the VSFG experimental setup is depicted in Figure 1. [1] Pulses centered at 800 nm, of 1 mJ energy at 1 kHz repetition rate from a commercial femtosecond (pulse duration 100 fs) laser system (Coherent) were used to generate tunable mid-IR pulses in an optical parametric generator/amplifier (TOPAS, Lightconversion) and 0.5 mJ to generate the narrow band visible field centered at 800 nm (with a bandwidth of 25 cm^{-1} using an etalon). The polarization of both infrared and visible beams were controlled by polarizers and $\lambda/2$ -plates and the beams were focused onto the sample using $f = 5$ cm and $f = 30$ cm lenses, respectively. The beam diameters in the focus are approximately 100 μm . The incident angles in the vertical plane are, respectively, 35° and 40° for the visible and infrared field. The SFG light was spectrally dispersed by an Acton monochromator. Typical SFG signals from an aqueous interface is very weak (~ 1 photon/pulse). Therefore, a sensitive Electron-Multiplying CCD (EMCCD detector newton DU970N-BV made by Andor Technology) is used to detect the SFG light generated.

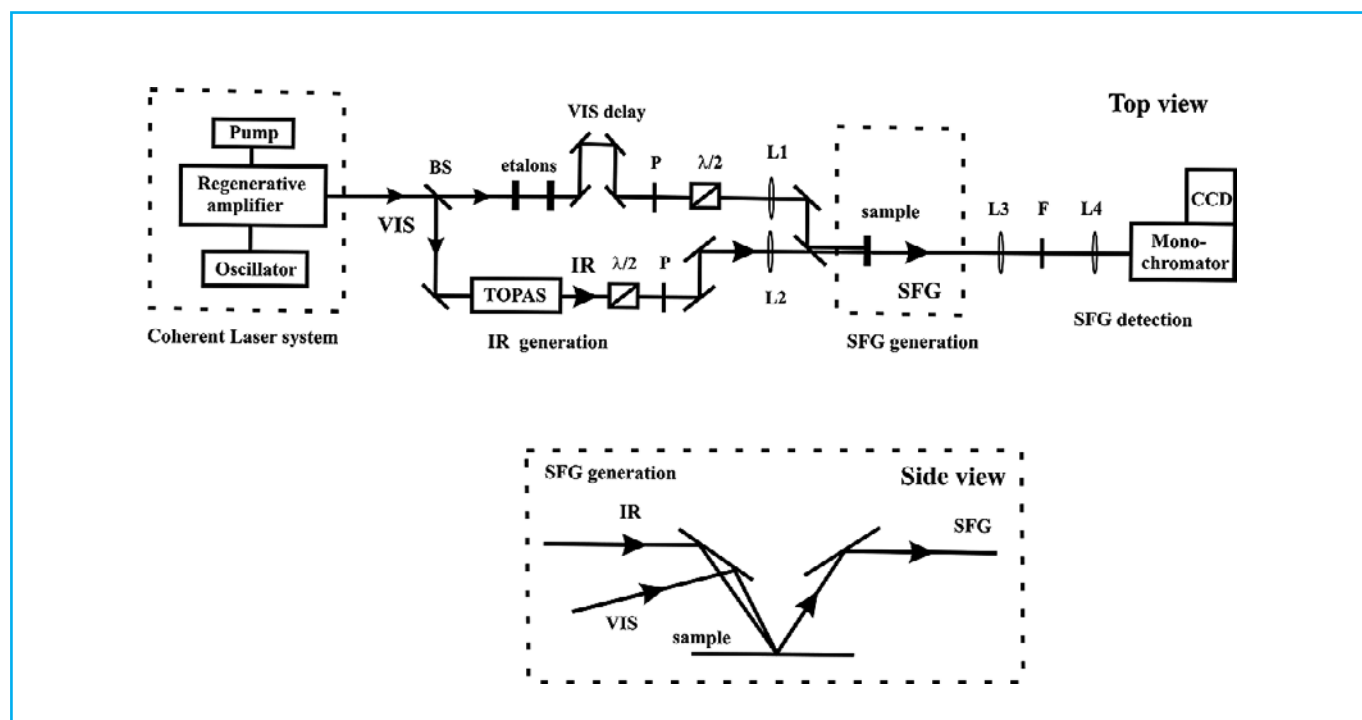

Figure 1. Schematic representation of the broad-bandwidth VSFG setup. The output from the regenerative amplifier is split into two parts using a beamsplitter (BS): one part is used to pump an optical parametric generator/amplifier (TOPAS) with a difference frequency unit to produce the broad-bandwidth IR-pulses; the other part is passed through an etalon to produce narrow-bandwidth VIS-pulses. The polarization of the two beams is controlled by using a $\lambda/2$ -plate (to rotate the polarization) and a polarizer (P, to clean the polarization). The two beams are focused with two lenses (L1 and L2 with focal lengths $f = 30$ and 5 cm, respectively) onto the sample and the signal beam is collected using a collimating lens, L3 ($f = 10$ cm). Finally, the signal beams are focused onto the slit of the spectrometer using a fourth lens (L4, $f = 5$ cm). The residual visible (800 nm) light is filtered out using a short wave pass filter (SWP). The signal is spectrally analyzed using an Acton monochromator, coupled to an Andor EMCCD camera. The bottom panel depicts a side view of the detection part of the setup.

Maria Sovago, Mischa Bonn (November 2009)

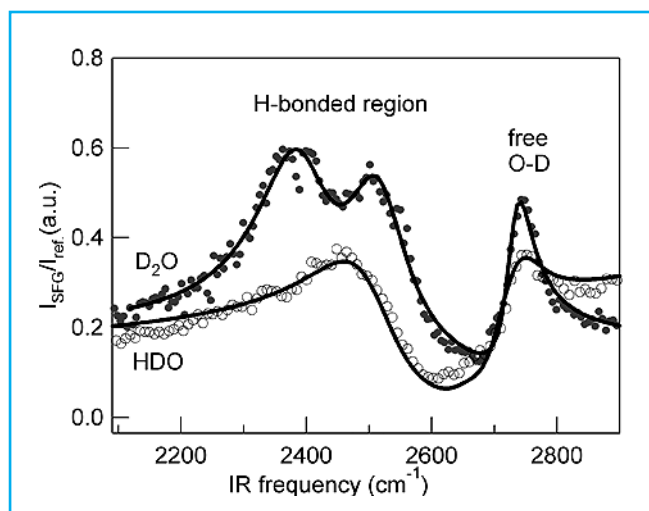

Figure 2. VSFG spectra of the heavy water/air interface. Fits to the data are shown by the thin solid lines. Peak positions are indicated in the graph. For pure D₂O (closed circles), two resonances are clearly identified in the O-D stretch region. For the isotopic mixture (H₂O:D₂O 2:1), the signal from HDO water molecules dominates the spectrum. The HDO spectrum appears as a single resonance in the H-bonded region, demonstrating that the signal originates from intra-molecular coupling.

Results

The VSFG spectrum of the heavy water-air interface is shown in Figure 2. It contains spectral features originating from specific interfacial water molecules: the 'free-OD' from water molecules with an O-D bond protruding from the surface (~ 2740 cm⁻¹), as its frequency is similar to the O-D stretch vibration in gas phase, and two peaks in the H-bonded frequency region (centered around 2400 and 2500 cm⁻¹, respectively). These two peaks contain details about the interfacial water structure; however their assignment has been much debated. By using isotopic dilution experiment (H₂O:D₂O 2:1), we provide a completely new assignment of the double-peak structure of the vibrational spectrum of the interfacial water. Our results reveal that the vibrational response originate from symmetric stretch vibrations split by a Fermi resonance (FR) with the overtone of the water bending mode. [2] This assignment is general for interfacial water, and shows that the interfacial water structure is structurally more homogeneous and simpler than previously thought.

References

- [1] M. Smits, M. Sovago, G. W. H. Wurpel, D. Kim, M. Muller, M. Bonn, *J. Phys. Chem. C* 111 (2007) 8878.
- [2] M. Sovago, R. K. Campen, G. W. H. Wurpel, M. Muller, H. J. Bakker, M. Bonn, *Phys. Rev. Lett.* 100 (2008) 173901.

Contact

Prof. Mischa Bonn
Biosurface Spectroscopy
FOM-Institute for Atomic and Molecular Physics
Sciencepark 104

1098 XG Amsterdam
The Netherlands

Phone: +31 20 754 7100

E-mail: m.bonn@amolf.nl

www.amolf.nl/research/biosurface-spectroscopy